

Silicon Field Stop(FS) Trench IGBT

Description

The THG40T65FBK is use advanced field stop(FS) trench technology. The 650V FS Trench IGBT offers superior conduction and switching performances.

General Features

- High Speed Switching & Low Power Loss
- Low saturation voltage: $V_{CE(sat)} = 1.95V @ I_c = 40A$
- $E_{off} = 0.3mJ @ T_c = 25^{\circ}C$
- Maximum junction temperature $175^{\circ}C$

Application

- Solar Converters
- Welding Converters
- UPS
- PFC
- PV Inverter

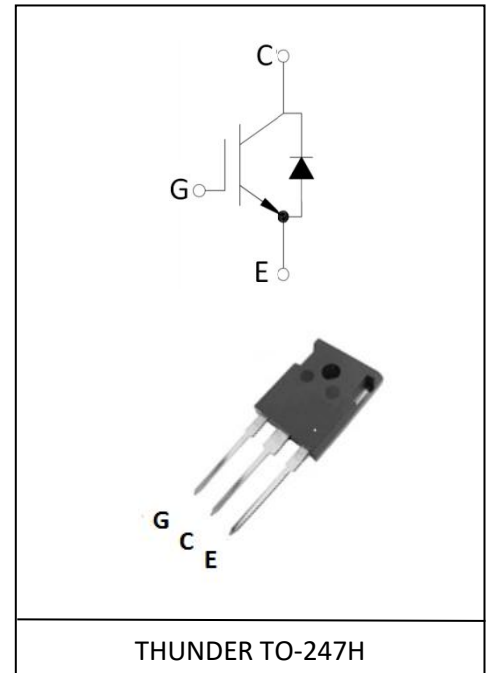

Absolute Maximum Ratings @ $T_c=25^{\circ}C$ (unless otherwise specified)

Symbol	Parameter	Value	Units
V_{CES}	Collector-Emitter Voltage	650	V
V_{GES}	Gate-Emitter Voltage	± 20	V
I_c	Collector Current	80	A
	Collector Current @ $T_c=100^{\circ}C$	40	A
I_{CM}	Pulsed Collector Current	160	A
I_F	Diode Continuous Forward Current @ $T_c=100^{\circ}C$	20	A
I_{FM}	Diode Maximum Forward Current	80	A
	Total Dissipation at @ $T_c = 25^{\circ}C$	280	W
	Total Dissipation at @ $T_c = 100^{\circ}C$	140	
T_j	Operating Junction and Storage Temperature Range	-55 to +175	$^{\circ}C$
T_L	Max Temperature For Soldering	260	$^{\circ}C$
T_{SC}	Short circuit withstand time $V_{GE}=15V, V_{CC} \leq 400V$, Allowed number of short circuits<1000Time between short circuits: $\geq 1.0s, T_j \leq 150^{\circ}C$	5	us

Electrical Characteristics @ T_c=25°C (unless otherwise specified)

Symbol	Parameter	Test Conditions	Min	Typ	Max	Unit	
Static Characteristics							
V _{CES}	Collector-Emitter Voltage	V _{GE} =0V, I _{CE} =250μA	650	—	—	V	
V _{CE(sat)}	Collector-Emitter Saturation Voltage	V _{GE} =15V, I _C =40A	T _J = 25°C	—	1.95	2.40	V
			T _J = 175°C	—	2.15	—	V
V _{GE(th)}	Gated Threshold Voltage	V _{CE} =V _{GE} , I _C =0.5mA	4.0	5.0	6.0	V	
I _{CES}	Collector-Emitter Leakage Current	V _{GE} =0V, V _{CE} =650V	—	—	10	uA	
I _{GES(F)}	Gate to Emitter Forward Leakage	V _{GE} = +20V, V _{CE} = 0V	—	—	200	nA	
I _{GES(R)}	Gate to Emitter Reverse Leakage	V _{GE} = -20V, V _{CE} = 0V	—	—	-200	nA	
Dynamic Characteristics							
C _{ies}	Input Capacitance	V _{GE} =0V, V _{CE} =25V, f=1.0MHZ	—	3600	—	pF	
C _{oes}	Output Capacitance		—	210	—	pF	
C _{res}	Reverse Transfer Capacitance		—	139	—	pF	
Q _g	Total Gate Charge	V _{CE} =480V, I _C =40A, V _{GE} =15V	—	186	—	nC	
Q _{ge}			—	42	—		
Q _{gc}			—	76	—		
Switching Characteristics							
t _{d(on)}	Turn-on Delay Time	V _{CE} =400V, I _C =40A V _{GE} =15V, R _G =10 Ω	—	30	—	nS	
t _r	Rise Time		—	24	—		
t _{d(off)}	Turn-off Delay Time		—	170	—		
t _f	Fall Time		—	22	—		

Electrical Characteristics of the Diode @T_c= 25°C unless otherwise specified

Symbol	Parameter	Test Conditions	Min	Typ	Max	Unit
I _F	Diode Continuous Forward Current	T _C = 100°C	20	—	—	A
I _{FM}	Diode Maximum Forward Current	T _C = 100°C	100	—	—	A
V _F	Diode Forward Voltage	I _F = 20A	—	1.75	2.15	V
t _{rr}	Reverse Recovery Time	T _J =25°C, I _F =20A	—	240	—	nS
Q _{rr}	Reverse Recovery Charge	di/dt=200A/us	—	4.9	—	nC
*Pulse Test: Pulse Width ≤ 300μs, Duty Cycle ≤ 2%						

Thermal Characteristic

Symbol	Paramter	Typ	MAX	Units
$R_{\theta JC}$	Themal Resistance,Junction to case for IGBT	--	0.52	$^{\circ}\text{C}/\text{W}$
$R_{\theta JC}$	Themal Resistance,Junction to case for Diode	--	0.79	$^{\circ}\text{C}/\text{W}$
$R_{\theta JA}$	Themal Resistance,Junction to Ambient	--	40	$^{\circ}\text{C}/\text{W}$

Typical Performance Characteristics

Figure 1 Output Characteristics

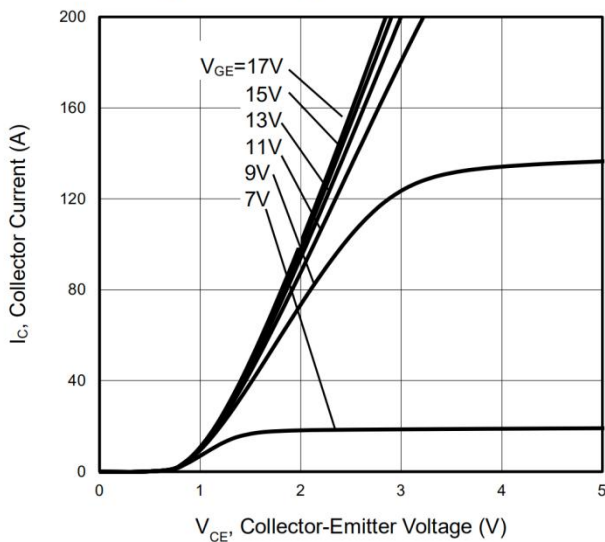

Figure 2 Transfer Characteristics

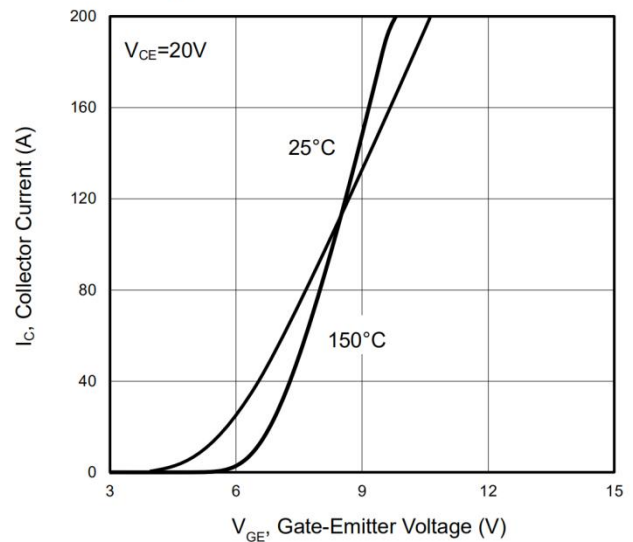

Figure 3 $V_{CE(sat)}$ vs. Temperature

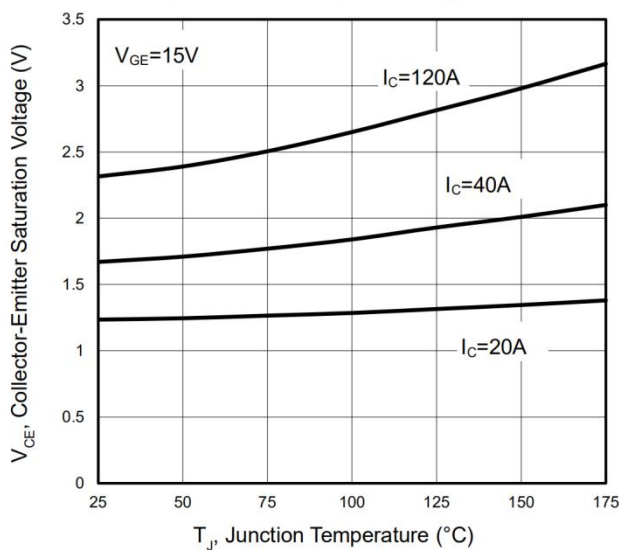

Figure 4 Saturation Voltage vs. V_{GE}

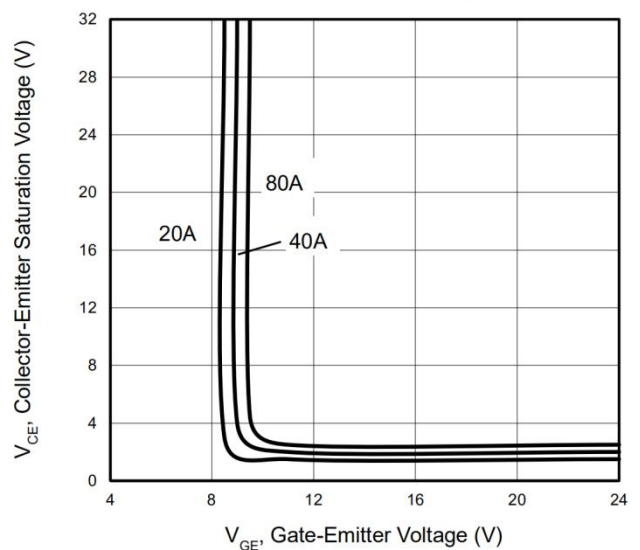

Figure 5 Capacitance Characteristics

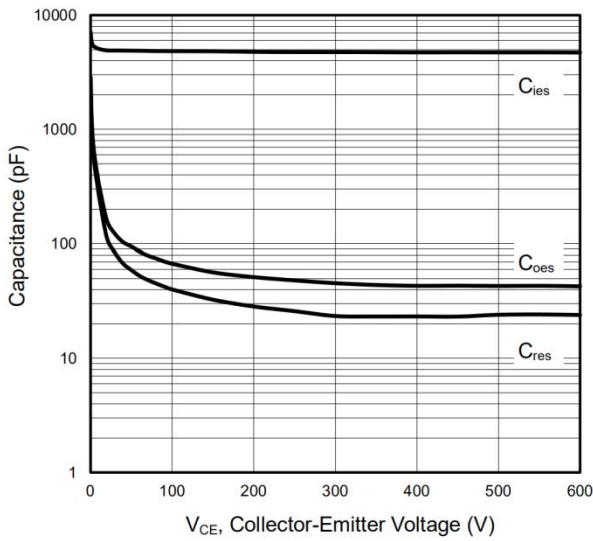

Figure 6 Gate Charge Wave Form

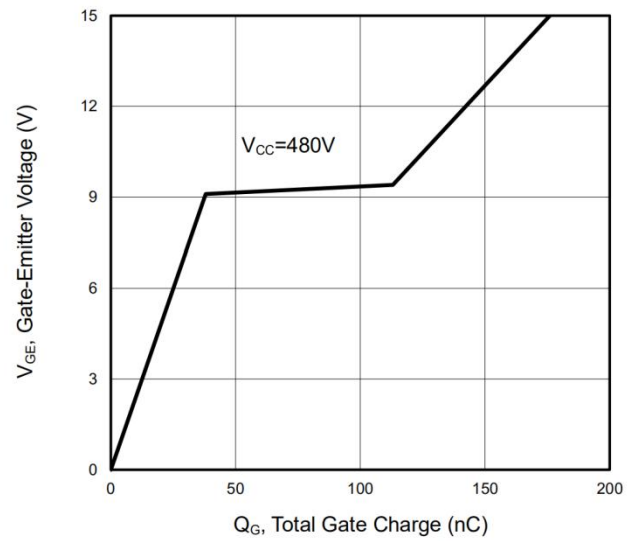

Figure 7 Forward Characteristics

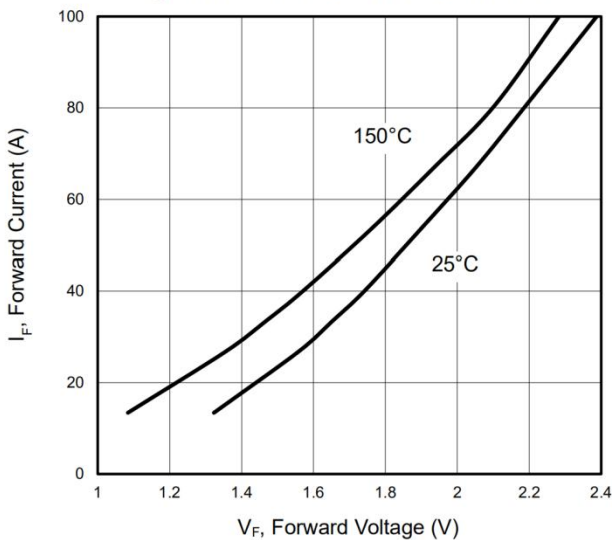

Figure 8 V_F vs. Temperature

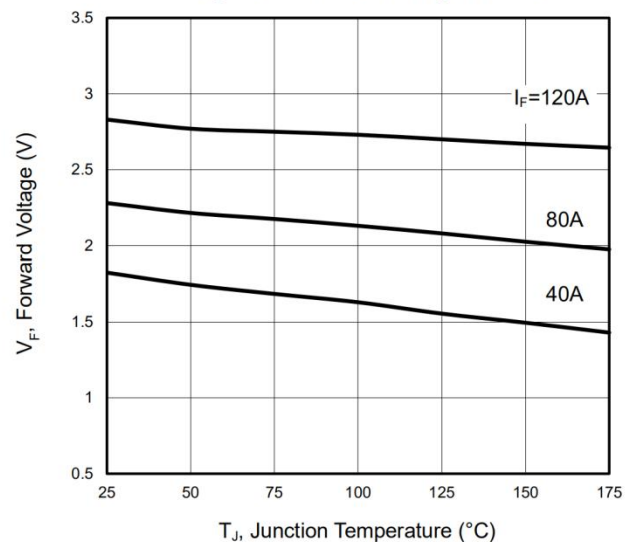

Figure 9 Switching Loss vs. R_G

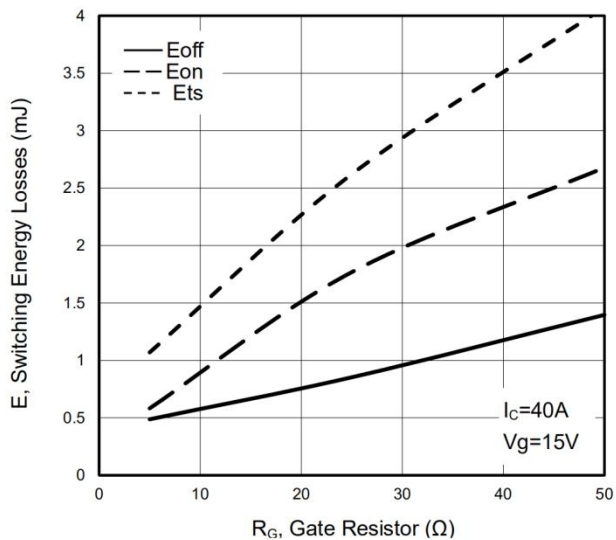

Figure 10 Switching Energy vs. Temperature

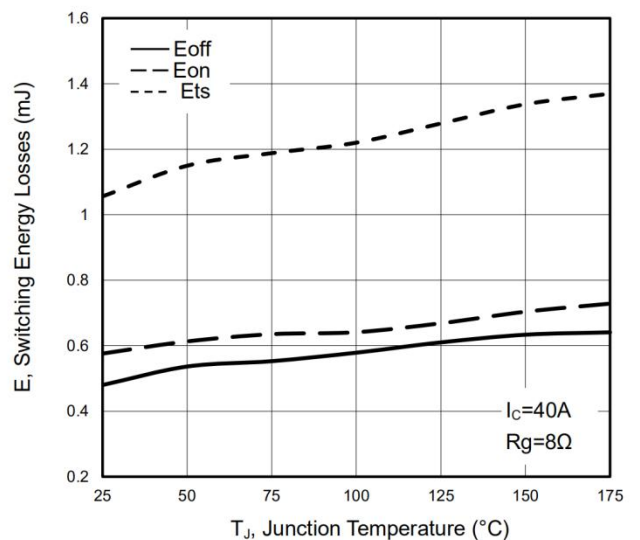

Figure 11 Switching Loss vs. Collector Current

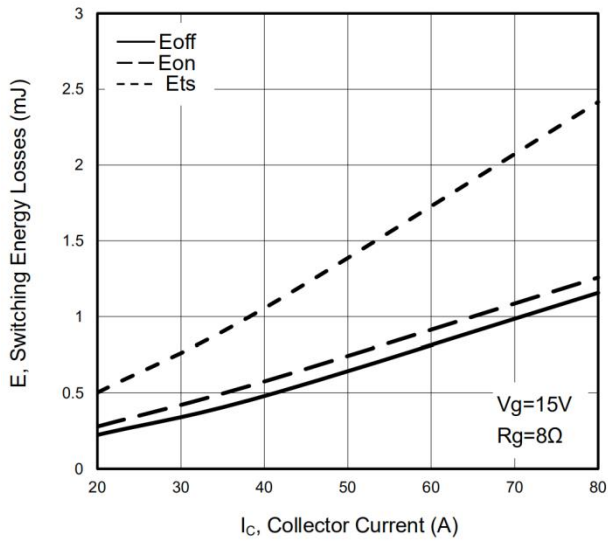

Figure 12 Switching Loss vs. Collector Current

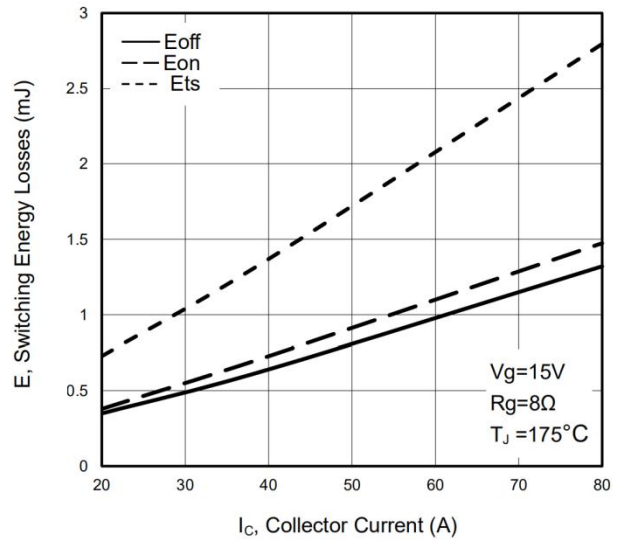

Figure 13 $V_{GE(th)}$ vs. Junction Temperature

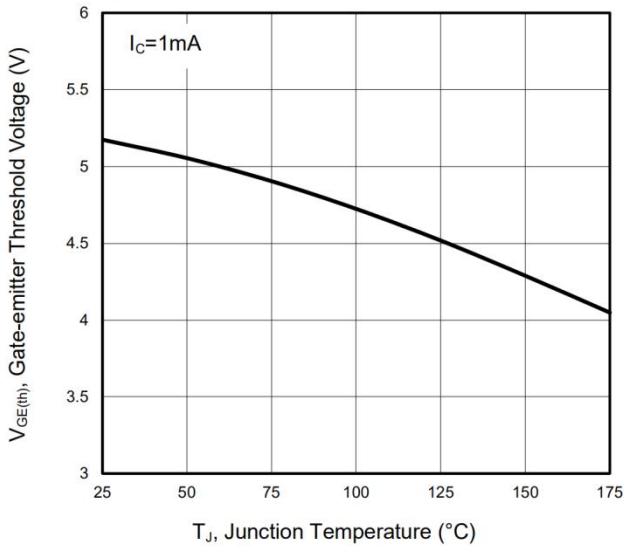

Figure 14 $V_{CE(sat)}$ vs. Collector Current

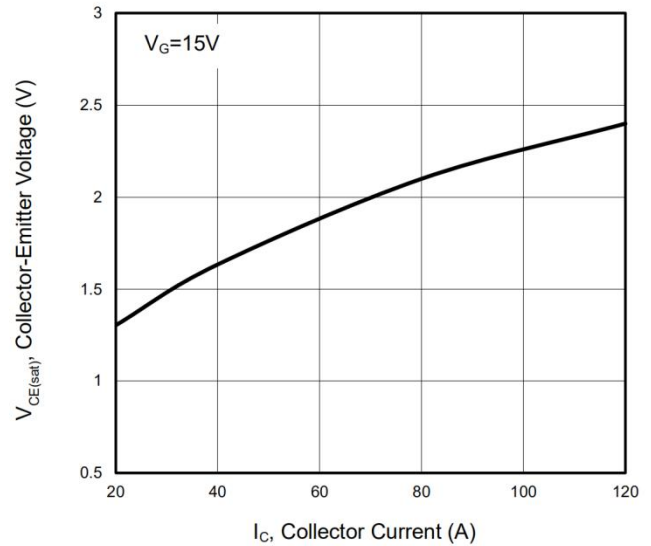

Figure 15 Forward Bias Safe Operating Area

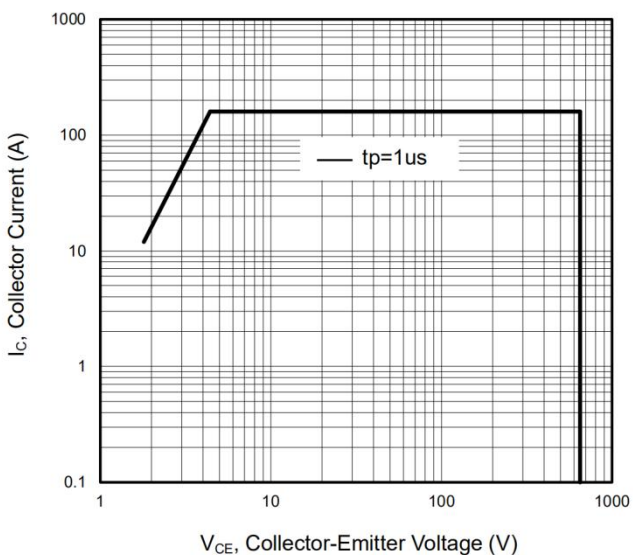

Figure 16 P_{tot} vs. Case Temperature

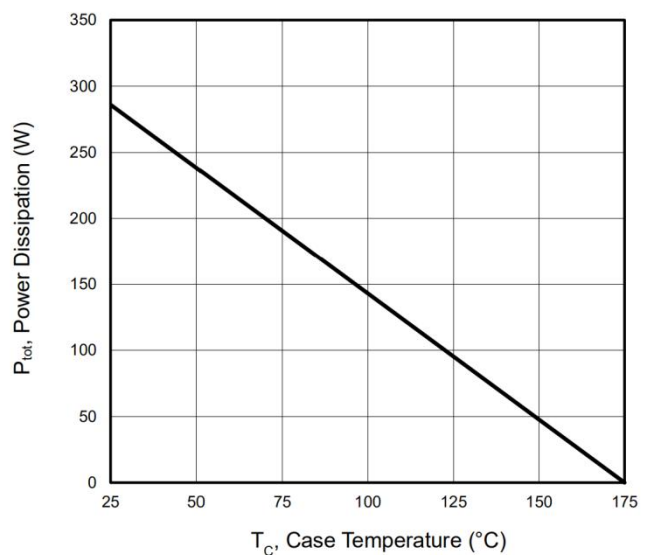

Figure 17 V_{CES} vs. Temperature

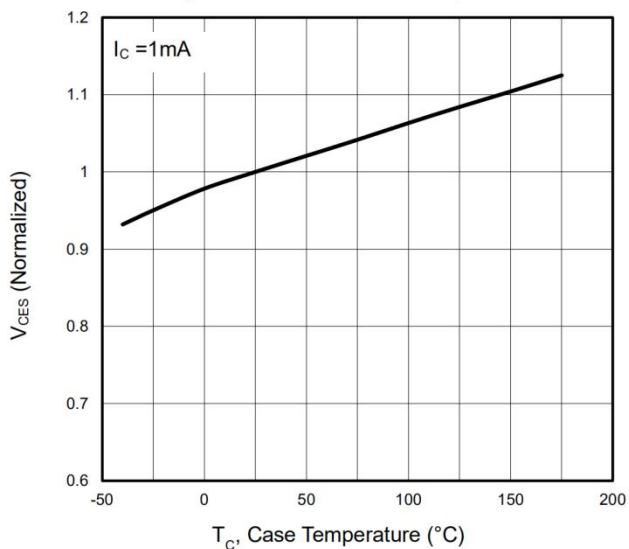

Figure 18 I_C vs. Temperature

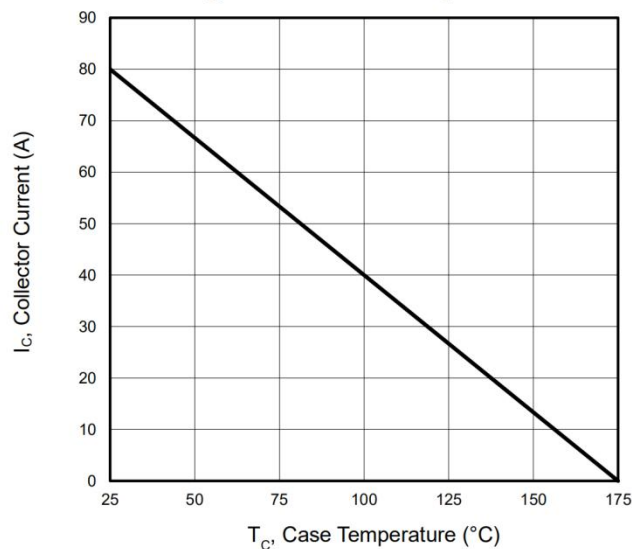

Figure 19 Switching Time vs. I_C

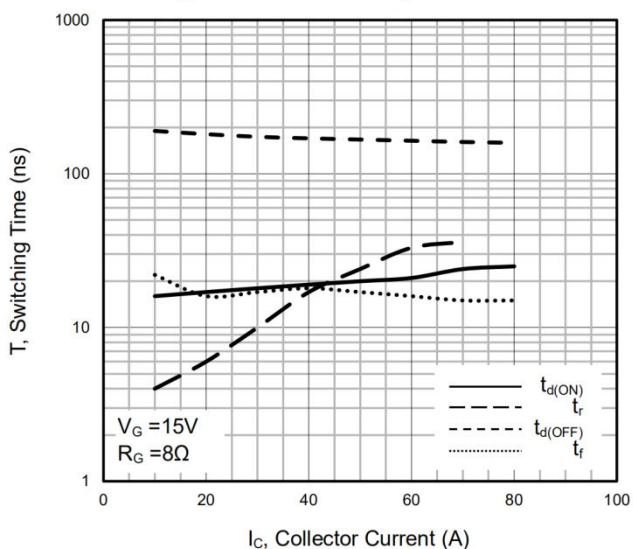

Figure 20 Switching Time vs. R_G

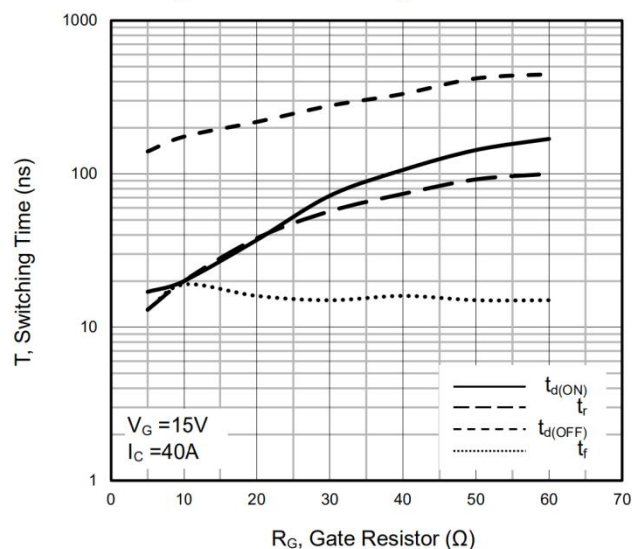

Figure 21 Switching Time vs. I_C

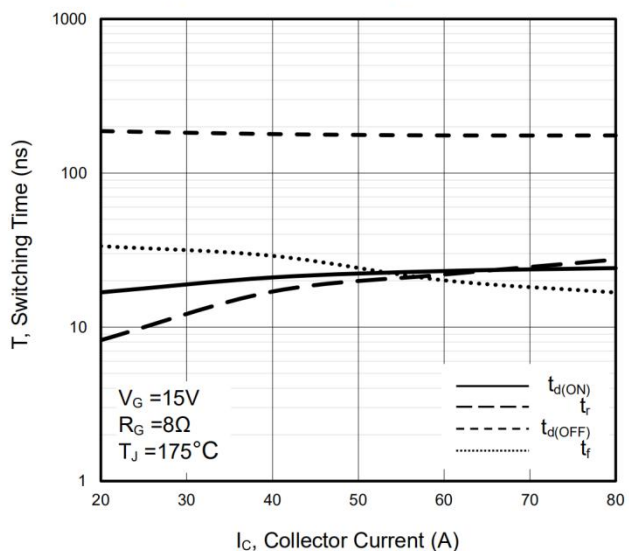
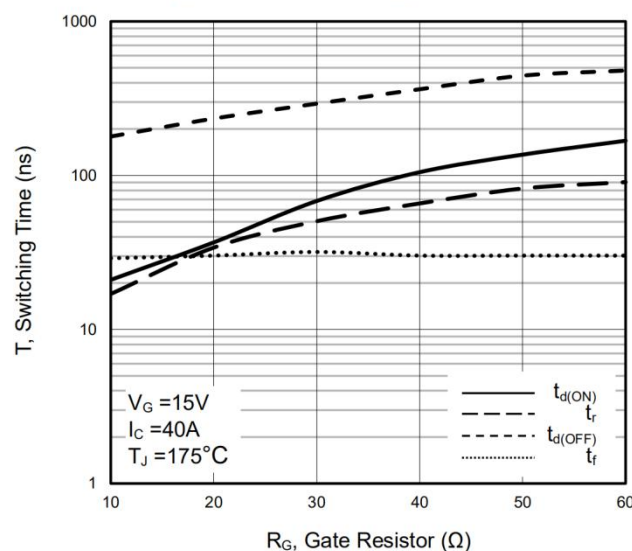
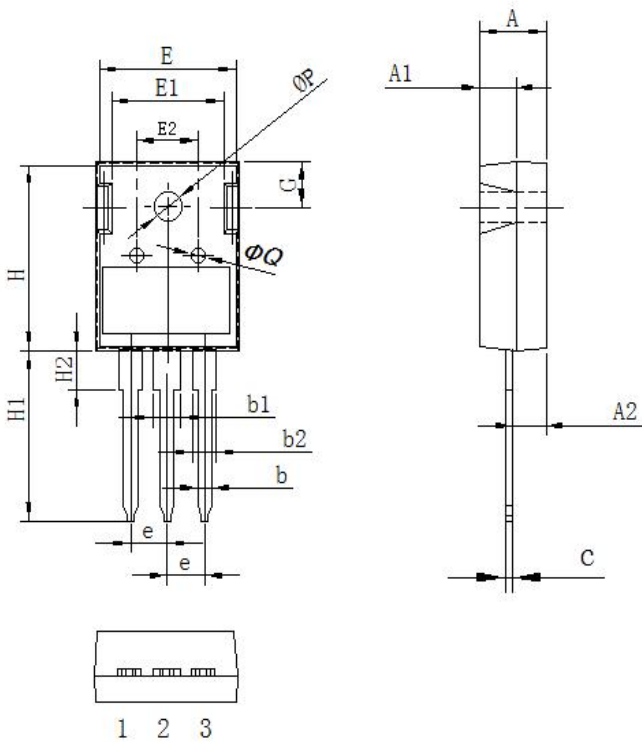

Figure 22 Switching Time vs. R_G



Package Information

TO-247H PACKAGE



Symbol	单位 mm		
	Min	Nom	Max
A	4.80	5.00	5.20
A1	2.80	3.00	3.20
A2	2.20	2.40	2.60
b	1.05	1.20	1.35
b1	2.80	3.00	3.20
b2	1.80	2.00	2.20
c	0.50	0.60	0.70
e	5.35	5.45	5.75
E	15.6	15.80	16.0
E1	12.3	12.50	12.7
E2	6.00	6.20	6.40
H	20.5	21.0	21.5
H1	19.0	20.0	21.0
H2	3.00	4.00	5.00
G	5.70	5.90	6.10
ΦP	3.30	3.50	3.50
ΦQ	2.30	2.50	2.70

Notice

Thunder Microelectronics Incorporated Limited reserves the right to make changes without further notice to any products or specifications herein. When use the product, be sure to obtain the latest specification.

Thunder Microelectronics Incorporated Limited does not assume any liability arising out of the application or any product described herein. When using Thunder Microelectronics Incorporated Limited products in your equipment, you are requested to take adequate safety measures to prevent the equipment from causing a physical injury ,fire or other problem if any of the products become faulty.

-Headquarters

WuXi Thunder Microelectronics Incorporated Limited
 Building E1-901, No.200 LingHu Road, XinWu district, WuXi, China 214135
 Tel:+86-510-85160109 Fax:+86-510-85160109